

DRAWING NO. **30-625M**

DATE	SYM	REVISION	DR

**\*\* THIS IS A STANDARD LOWER GEAR ASSY, IF YOURS IS A CUSTOM ASSY, PLEASE CONTACT THE FACTORY TO VERIFY CORRECT COMPONENTS**

**\* SOLD AS GEAR SET 30-204**

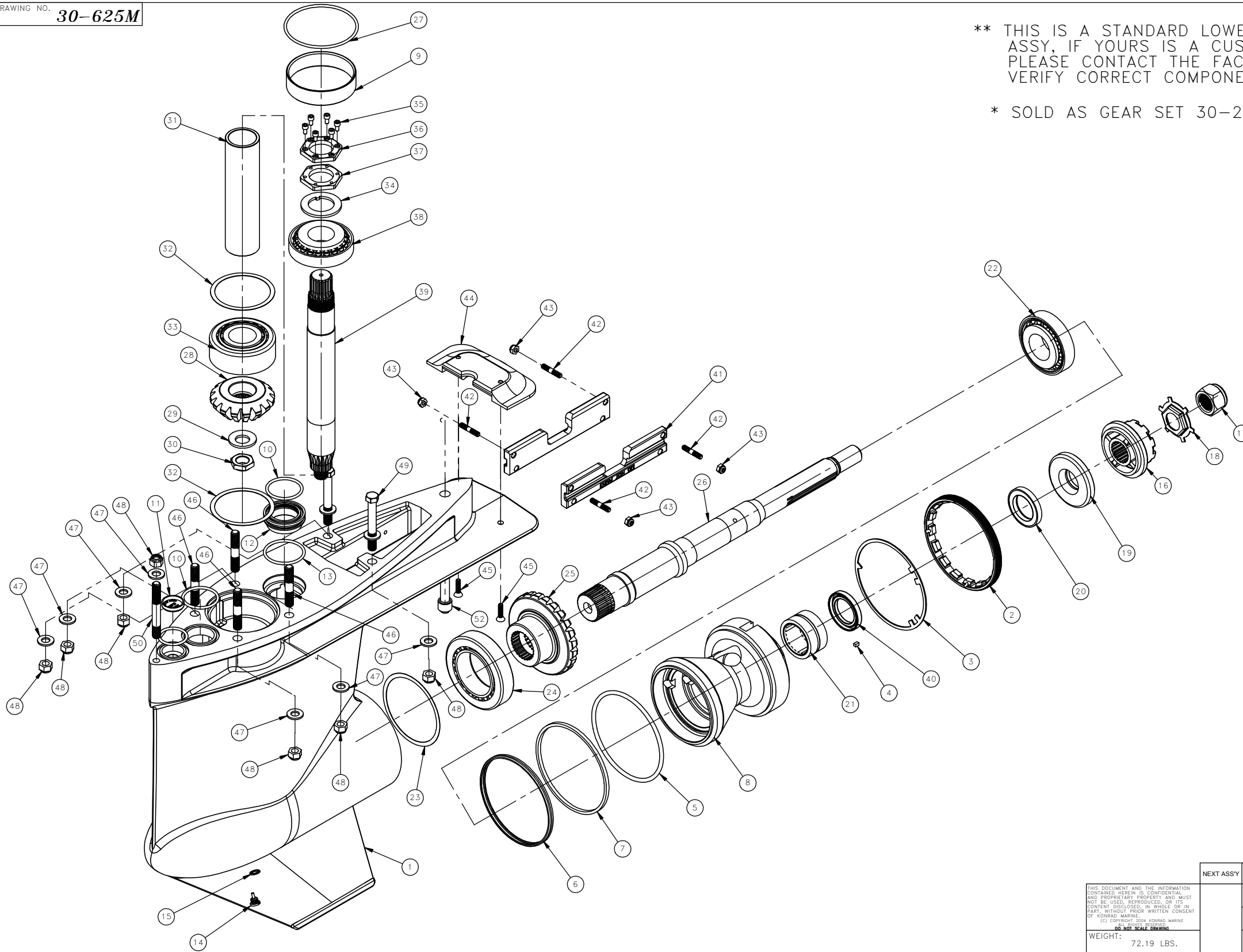

52	11-237	S.H.C.S., SS	1
51	13-021	O-RING	1
50	13-020	STUD	1
49	13-022	CAP SCREW, H.H.	2
48	10-314	NYLOCK NUT, BRS	7
47	10-457	WASHER, FLAT S.S.	9
46	13-001	STUD	4
45	10-461	F.H.C.S.	2
44	10-432	PLATE, INHIBITOR	1
43	10-333	NUT, NYLOCK, BRS	4
42	10-253	STUD	4
41	10-433	PLATE, INHIBITOR	2
40	10-291	SEAL	1
39	10-200	SHAFT, VERTICAL, BOTTOM	1
38	10-259	BEARING	1
37	10-573	NUT, LOCKING	1
36	10-574	NUT, LOCKING	1
35	10-578	S.H.C.S.	6
34	10-526	WASHER, TONGUED	1
33	10-377	PINION BEARING	1
32	10-288	SET, SHIM	2
31	10-557	SPACER, LOWER HSG	1
30	10-260	LOCKNUT, STAKE	1
29	10-358	WASHER, BELLEVILLE	1
* 28	10-261	PINION, 16 TOOTH, VERTICAL	1
27	10-400	O-RING	1
* 26	10-360	SHAFT, PROP, LH	1
* 25	10-258	GEAR, 24 TOOTH, HORIZON	1
24	10-269	BEARING	1
23	10-299	SHIM SET	1
22	10-509	BEARING	1
21	10-394	BEARING, ROLLER	1
20	10-639	SEAL	1
19	10-292	THRUST HUB	1
18	10-295	WASHER, TAB	1
17	10-296	LOCKNUT, NYLON	1
16	10-293	WASHER, SPLINED	1
15	10-285	WASHER, SEAL	1
14	10-155	PLUG, DRAIN, MAGNETIC	1
13	12-698	O-RING	1
12	12-817	PLUG, OIL FLOW	1
11	10-669	PLUG, EXPANSION	1
10	10-399	O-RING	2
9	12-816	SLEEVE, ALIGNMENT	1
8	12-797	CARRIER, BEARING	1
7	12-799	WASHER, THRUST	1
6	12-798	RING, LOAD	1
5	12-796	O-RING	1
4	10-017	KEY	1
3	12-784	WASHER, TAB	1
2	12-783	COVER, NUT	1
1	12-772	HOUSING LOWER, 620	1
ITEM NO.	PART NO.	DESCRIPTION	QTY.

**620  
LOWER  
GEAR  
HOUSING  
LH ASS'Y**

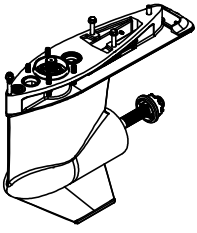

<small>THIS DOCUMENT AND THE INFORMATION CONTAINED HEREIN IS CONFIDENTIAL AND PROPRIETARY PROPERTY AND MUST NOT BE USED, REPRODUCED, OR ITS CONTENT DISCLOSED, IN WHOLE OR IN PART, WITHOUT PRIOR WRITTEN CONSENT OF KONRAD MARINE. © COPYRIGHT 2004 KONRAD MARINE DO NOT SCALE DRAWING</small>	NEXT ASSY'	TOLERANCE	<b>Konrad</b>	
	.X ± .020	MAT'L:	SCALE: DRAWN BY: SC	1:2.5 APP.BY:
	.XX ± .010	TITLE:	<b>620 LOWER GEAR HOUSING ASS'Y, L.H</b>	
	.XXX ± .005	DATE:	DRAWING NUMBER <b>30-625M</b>	
WEIGHT:	72.19 LBS.	DATE:	9/27/13	